

PFAFF[®] Industrial



POWERLine 2231



POWERline 2231

02 // 03 Philosophy

Philosophy

The POWERLINE 2231 is a high-speed seamer featuring bottom feed and needle feed – another solution from the POWERLINE-model kit. This PFAFF INDUSTRIAL product closes the gap between the classic high-speed seamer and a heavy special high-speed seamer featuring unison feed.

The 2231 ensures good-quality seams and sewing reliability for top-stitching and assembling seams in the medium heavy segment (e. g. medium heavy fabrics, jeans and leather goods). Moreover, it yields excellent seam results. With the largest workspace of its class the POWERLINE 2231 guarantees superb handling even with voluminous parts.

The 2231 is characterized by trend-setting ergonomics, its striking design and the innovative service concept.



Overview of the 2231

The POWERLINE 2231 is offered in PLUS version with different functions.

	PLUS
Horizontal hook, large (for threads up to size 15/3 syn.)	●
Thread trimmer, <12 mm (-900/91)	●
Thread nipper, controlled (-909/12)	○
Presser foot lift, manual by knee lever	○
Presser foot lift, electro-pneumatically (-910/04)	●
Manual backtacking with hand lever	●
Automatic backtacking, electro-pneumatically (-911/35)	●
1 pre-selectable stitch length	●
2 pre-selectable thread tensions, one can be switched on manually	●
Compound feed	●
Oil-level indicator	●
Sewing feet pressure, manually adjustable	●
DC pico drive P45 PD2-L	●
Control panel BDF-PicoTop	●
Bobbin thread monitor with stitch counter and LED display	●
In machine head integrated panel with multi-function buttons	●
Built in LED sewing light in the machine head, dimmable	○
Bobbin thread winder	●
Mounting facilities (in bed plate) for attachments	●
Overload safety clutch (built-in in hand wheel)	○

● standard
○ option

Standardversion

2231-521/001 PLUS

Single-needle special high-speed seamer with compound feed (lockstitch)

- Großer Horizontalgreifer für Fadenstärken bis 15/3
- Top feed stroke up to 9 mm, presser foot lift up to 20 mm, stitch length up to 9 mm
- Max. sewing speed 3,500 stitches/min.

Parts kits

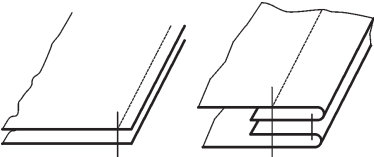
Parts kit	Seam construction	Operation
-6/01 N (N = 6 mm) B medium weight material C heavy weight material		Standard parts kit for all types of sewing work, e.g.: <ul style="list-style-type: none"> • Closing seams • Edge sewing work • Fancy seams
-6/01 N9 (N9 = 9 mm) C heavy weight material		

Edge guides

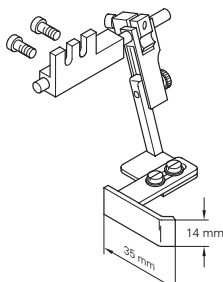
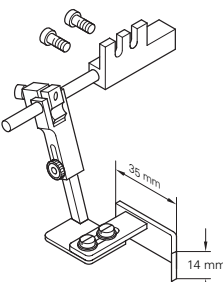
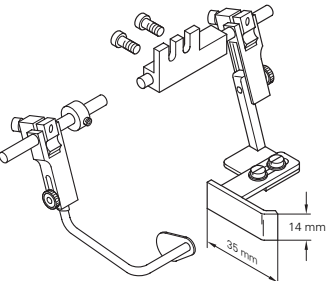
Edge guide	Parts No.	Suitable for parts kit
	91-156 763-91	-6/01 N -6/01 N9
	91-156 764-91	-6/01 N -6/01 N9
	91-156 765-91	-6/01 N -6/01 N9



Applications

Medium heavy assembly- and top-stitching seams on medium heavy fabrics (e.g. jeans) and leather materials

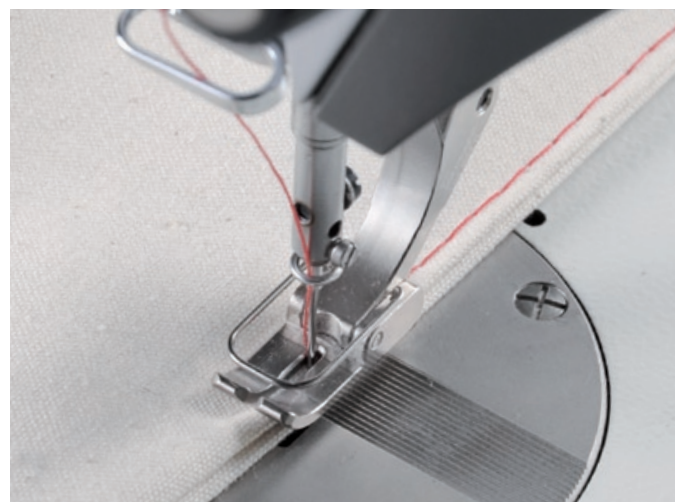

POWERline 2231

Innovative lubrication system

New lubrication system for accurate adjustment of the fresh oil supply to the hook. Prevents oil leakage (soiling of workpiece).

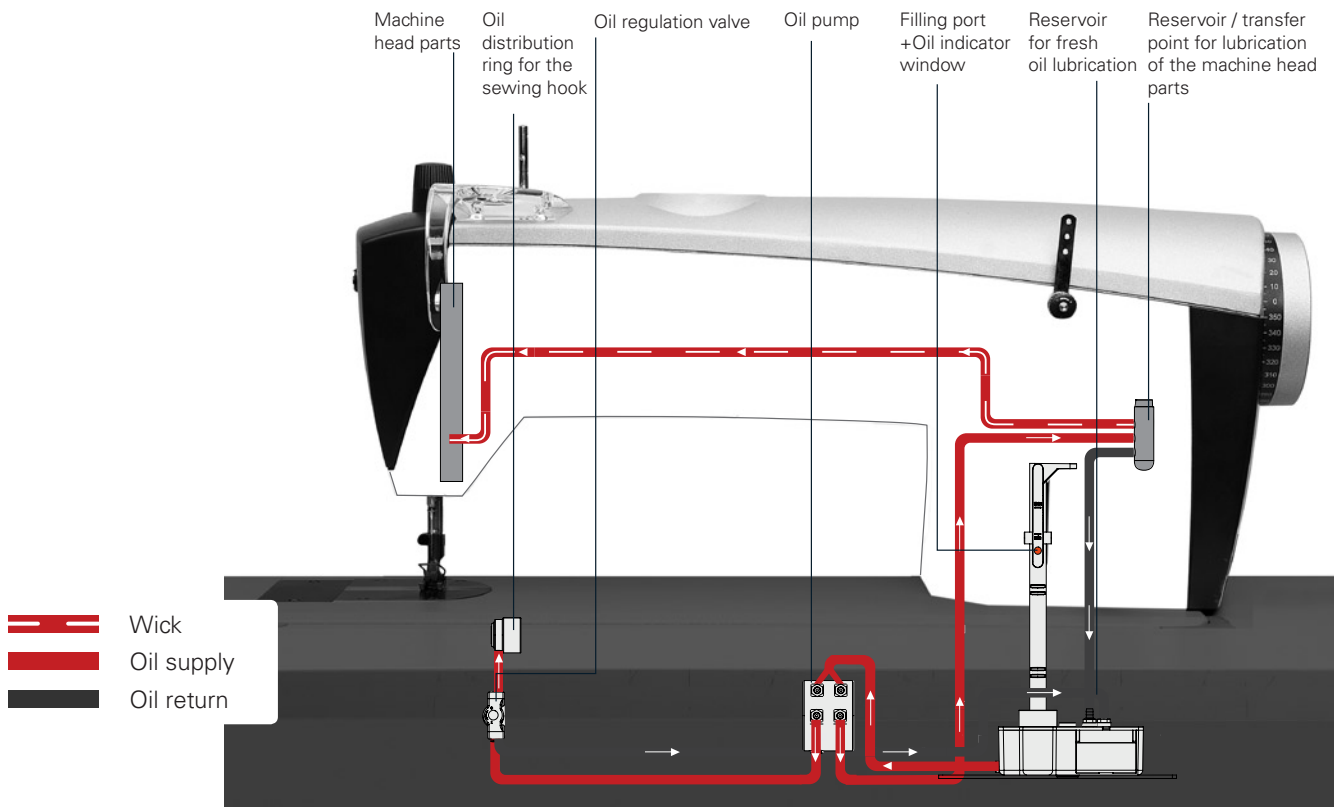

Unique service concept



Easy and fast access of all adjustments:
The top arm cover and the head cover can be removed after loosening just 3 screws.

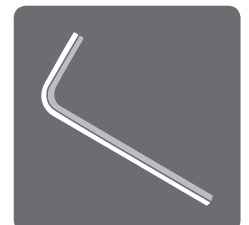

Features



①

Bobbin winder

Equipped with an aid for a secure and fast start of the bobbin winding process and within easy reach of the operator („winding assistant“)



②

Ergonomically designed and convenient placed control elements

Clear and precise functions:

- Reverse sewing/ intermediate backtacks
- Needle position change (w/o trimming)
- Switch for threading position and tension release
- Safety switch

POWERline 2231

Thread nipper

Ensures a neat seam start
(no thread tail on top of the
work piece) (option)

③



LED-Light (option)

Integrated in the sewing head

④



Large clearance

Under the machine arm
of 345 x 120 mm.

⑤



Scale disk

An adjustment aid for the mechanic

⑥







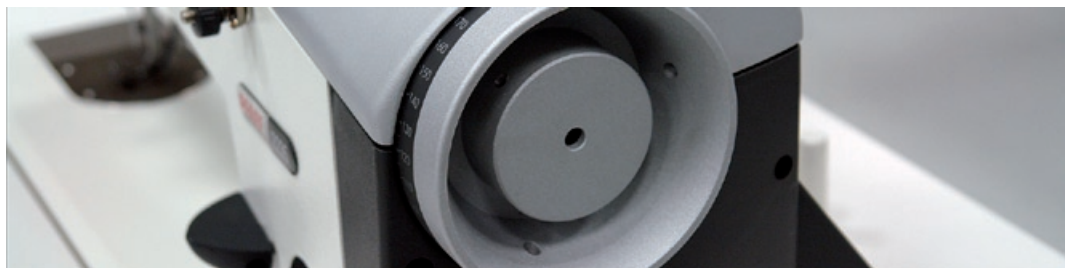

Overload safety clutch

To protect the hook and its drive
mechanism from mechanical seizures
(option)

⑦

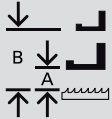

Technical data + Specifications

Typen	 max	 mm	Modell	 B A		 - System	 - Nm	 Nm
2231 PLUS 2231 - 521/001	3,500	max. 9	B/C	A: 9 mm B: 20 mm	≤ 12	134-35	80 - 140	max. 15/3



Max. sewing speed

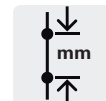









Max. stitch length in mm

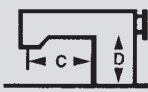

Top feed stroke (A) and fabric clearance (B)



Remaining thread length after cutting in mm

							
C:345 x D:120	●	●	●	●	○	●	●

● standard
○ option



Needle system



Recommended needle size in Nm



Thread size (metrical number in Nm)



Arm clearance in mm



Number of needles

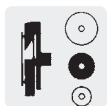

Horizontal hook, large



Thread trimmer

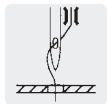

Thread nipper



Presser foot lift



Automatic back-tacking



Compound feed

PFAFF Industriesysteme und Maschinen AG

Hans-Geiger-Str. 12 – IG Nord
D – 67661 Kaiserslautern
www.pfaff-industrial.com

Telefon: +49-6301/3205-0
Telefax: +49-6301/3205-3171
E-mail: info@pfaff-industrial.com

