

PFAFF[®] Industrial



POWERline 2235



POWERline 2235

Philosophy



The fine tension of the surface signalizes power and dynamics, the design combines traditional forms with ergonomic elegance.

During the development of **the single-needle high-speed seamer, POWERLINE 2235, with triple feed (bottom, needle and alternating top feed) and horizontal hook**, the technicians and engineers at PFAFF focused on the essentials - and at the same time set new standards in the sewing machine world.

The main applications of the POWERLINE 2235, apart from the automotive and home upholstery sectors, are the small leather articles and technical textile branches. On assembly and top-stitch work on medium to heavy materials the machine guarantees extraordinary seam quality and sewing reliability. It also gives excellent results for top-stitching work. The Powerline 2235 has the largest arm clearance in its class and therefore this machine guarantees outstanding handling even on the most bulky parts.

The trend-setting ergonomics, the impressive design and the innovative service concept establish a new dimension in this class. The **interzum award 2007** in the Best of the best category confirms the leading concept of PFAFF.

Overview of the 2235

The POWERLINE 2235 is offered in three versions and with different functions

	BASIC	PLUS	PREMIUM
Horizontal hook, large (for threads up to size 15/3 syn.)	●	●	●
Horizontal hook, large (for threads up to size 10/3 syn.)	○	○	○
Thread trimmer, < 12 mm thread ends (-900/91)		●	●
Thread nipper, controlled (-909/12)		○	●
Presser foot lift, manual by knee lever	●		
Presser foot lift, electro-pneumatically (-910/04)		●	●
Manual backtacking with hand lever	●	●	●
Automatic backtacking, electro-pneumatically (-911/35)		●	●
1 pre-selectable stitch length	●	●	
2 pre-selectable stitch lengths, alternately switchable			●
2 pre-selectable thread tensions, one can be switched on manually	●	●	
2 pre-selectable thread tensions, one can be switched on electro-pneumatically by knuckle switch			●
1 top feed stroke is manually adjustable up to 9 mm	●	●	
2 top feed strokes are manually adjustable, pre-selectable quick-change stroke adjustment with hand lever (electro-pneumatically controlled)			●
Unison feed	●	●	●
Unison feed with engageable lifting motion of bottom feeder	○	○	○
Oil-level indicator	●	●	●
Oil-level indicator on the display, with warning light on sewing head			●
Sewing feet pressure, manually adjustable	●	●	●
Clutch motor	●		
DC-Motor PicoDrive *	○	●	
DC-Motor P74 ED			●
Bobbin thread monitor with stitch counter and LED display		●	●
Control panel BDF-PicoTop		●	●
In machine head integrated panel with multi-function buttons		●	
In machine head integrated panel with multi-function buttons and programmable multi-switch			●
Built in LED sewing light in the machine head, dimmable	○	○	●
Bobbin thread winder	●	●	●
Mounting facilities (in bed plate) for attachments	○	○	○
Skip stitch detection (SSD)			○
Overload safety clutch	○	○	●

* Necessary for thread trimmer, backtacking, thread nipper and presser foot lift

● standard
○ option

Versions

2235-021/000 BASIC

Single-needle special high-speed seamer with unison feed (lockstitch)

- Large horizontal hook for threads up to 15/3
- Top feed stroke up to 9 mm, presser foot lift up to 20 mm, stitch length up to 9 mm
- Max. sewing speed 3,000 stitches/min.

2235-032/000 BASIC

Single-needle special high-speed seamer with unison feed (lockstitch)

- Large horizontal hook for threads up to 10/3
- Top feed stroke up to 9 mm, presser foot lift up to 20 mm, stitch length up to 9 mm
- Max. sewing speed 2,800 stitches/min.

2235-521/001 PLUS

Single-needle special high-speed seamer with unison feed (lockstitch)

- Large horizontal hook for threads up to 15/3
- Thread trimmer, automatic presser foot lift, automatic backtacking device electro-pneumatically controlled
- Top feed stroke up to 9 mm, presser foot lift up to 20 mm, stitch length up to 9 mm
- Max. sewing speed 3,000 stitches/min.

2235-532/001 PLUS

Single-needle special high-speed seamer with unison feed (lockstitch)

- Large horizontal hook for threads up to 10/3
- Thread trimmer, automatic presser foot lift, automatic backtacking device electro-pneumatically controlled
- Top feed stroke up to 9 mm, presser foot lift up to 20 mm, stitch length up to 9 mm
- Max. sewing speed 2,800 stitches/min.

2235-821/001 PREMIUM

Single-needle special high-speed seamer with unison feed (lockstitch)

- Large horizontal hook for threads up to 15/3
- Thread trimmer, automatic presser foot lift, automatic backtacking device electro-pneumatically controlled
- Quick-change stepping control of top feed, second thread tension, quick adjustment of second stitch length (electro-pneumatically controlled)
- Top feed stroke up to 9 mm with automatic speed setting, presser foot lift up to 20 mm, stitch length up to 9 mm
- Max. sewing speed 3,000 stitches/min.
- Built in LED sewing light in the machine head
- DC motor
- Overload safety clutch

2235-832/001 PREMIUM

Single-needle special high-speed seamer with unison feed (lockstitch)

- Large horizontal hook for threads up to 10/3
- Thread trimmer, automatic presser foot lift, automatic backtacking device electro-pneumatically controlled
- Quick-change stepping control of top feed, second thread tension, quick adjustment of second stitch length (electro-pneumatically controlled)
- Top feed stroke up to 9 mm with automatic speed setting, presser foot lift up to 20 mm, stitch length up to 9 mm
- Max. sewing speed 2,800 stitches/min.
- Built in LED sewing light in the machine head
- DC motor
- Overload safety clutch

Applications



Pre-assembly work
in the automotive industry

Application:

Attaching an extra strip to the seat-back
of a front car seat with PVC-J-clip-piece

Parts sets / attachments:

parts kit 6/01 C N9
+ edge guide (91-156-763-91)



Pre-assembly work
in the automotive industry

Application:

Attaching side sections to the seat
centre piece

Parts sets / attachments:

parts kit 6/01 C N9
+ edge guide (91-156-763-91)



Pre-assembly work
in the automotive industry

Application:

Closing a side section seam

Parts sets / attachments:

parts kit 6/01 C N9
+ edge guide (91-156-763-91)



Lap seams
in the home upholstery industry

Application:

Top-stitching one side of the connection
seam of a chair back

Parts sets / attachments:

parts kit 6/01 C N9
+ edge guide (91-156-765-91)

Innovative lubrication system

New lubrication system for accurate adjustment of the fresh oil supply to the hook. Prevents oil leakage (soiling of workpiece).

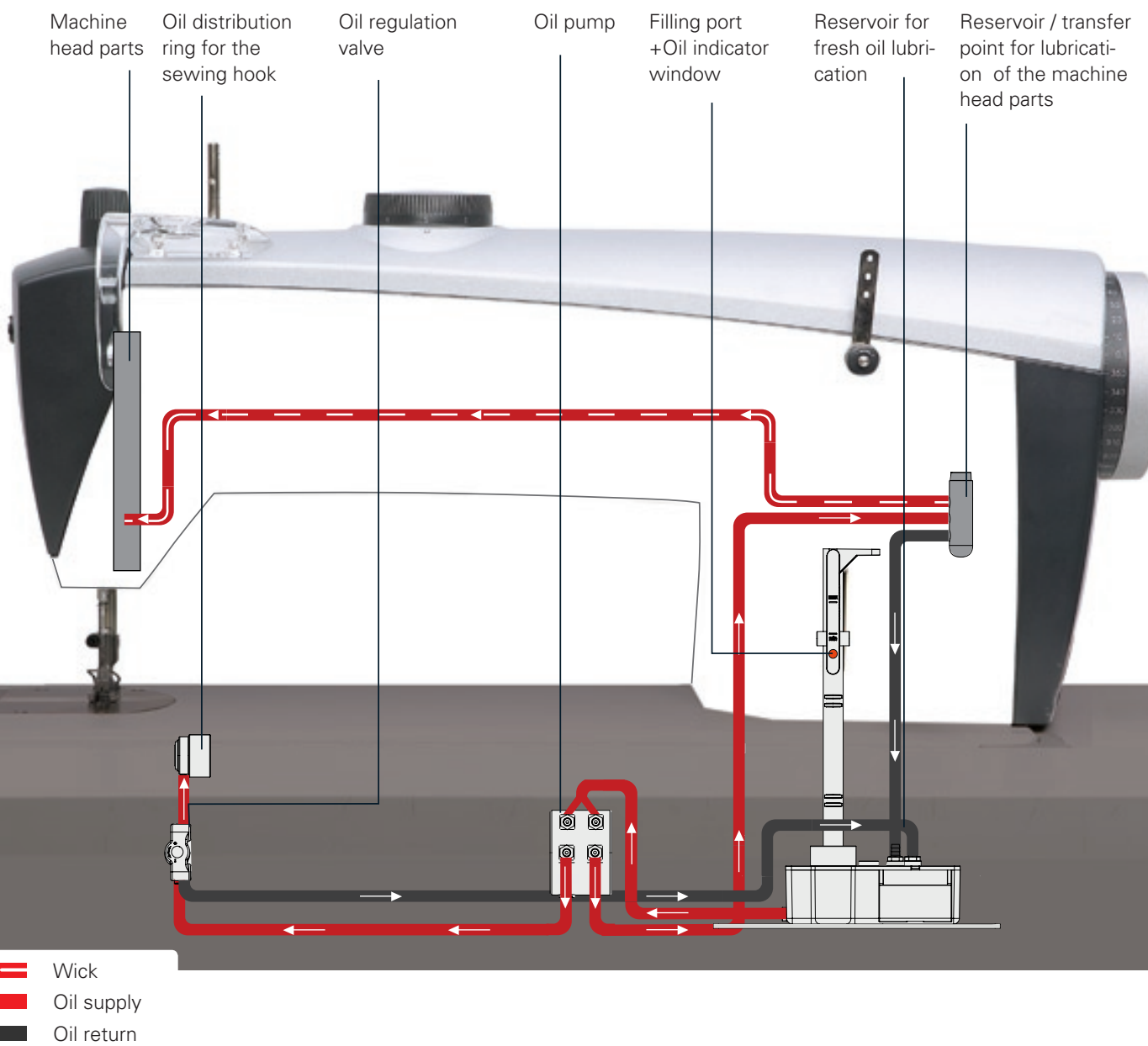

Features



①

Bobbin winder

Equipped with an aid for a secure and fast start of the bobbin winding process and within easy reach of the operator („winding assistant“)



②

Ergonomically designed and convenient placed control elements

Clear and precise functions:

- Reverse sewing/ intermediate backtacks
- Needle position change (w/o trimming)
- Switch for threading position and tension release
- Safety switch

POWERline 2235

Thread nipper

Ensures a neat seam start
(no thread tail on top of the
work piece)

③



LED-Light

Integrated in the sewing head

④



Increased top feed stroke

Up to 9 mm

Clearance under the sewing foot

Up to 20 mm

⑤-⑥

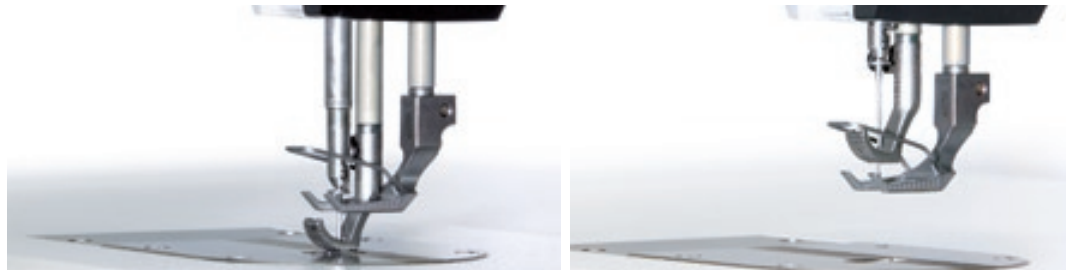

Large clearance

Under the machine arm
of 345 x 120 mm.

⑦



Scale disk

An adjustment aid for the mechanic

⑧



Overload saftey clutch

To protect the hook and its drive
mechanism from mechanical seizures

⑨

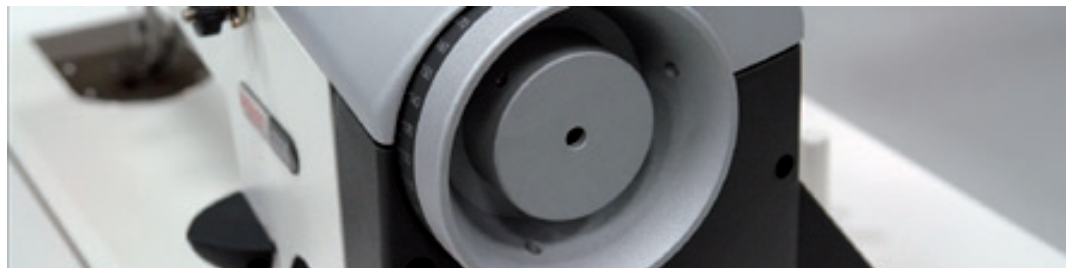

Unique service concept

Easy and fast access of all adjustments:
The top arm cover and the head cover can be removed after loosening just 3 screws.

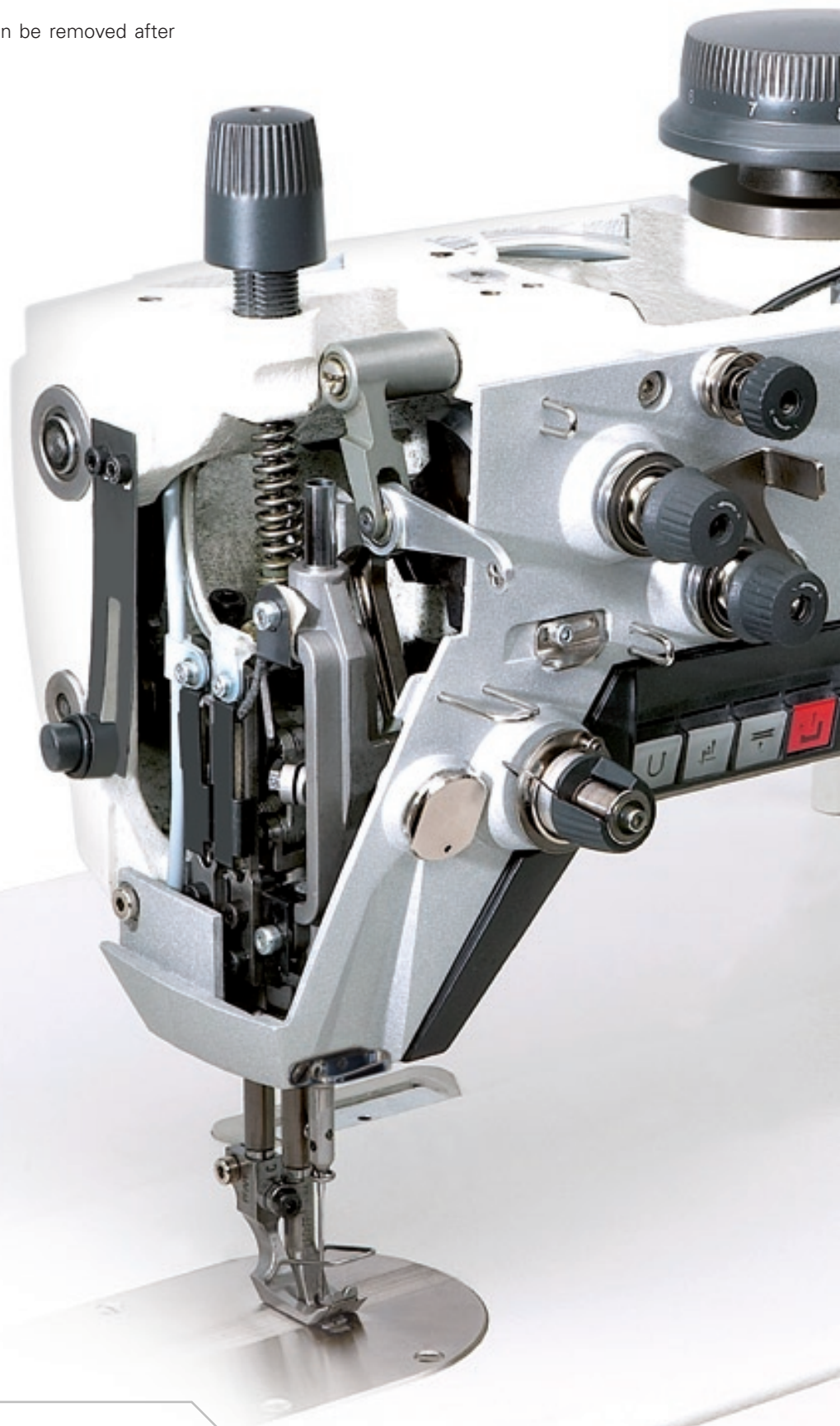

POWERline 2235



PFAFF 2235

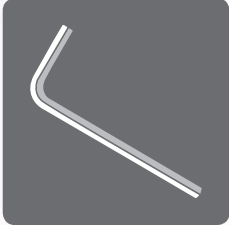

Parts kits

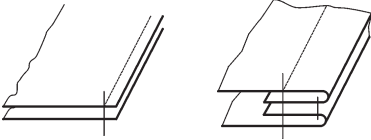
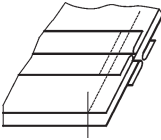
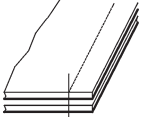
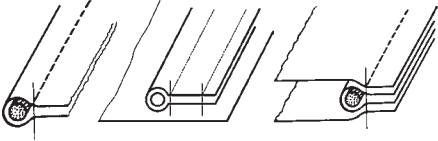
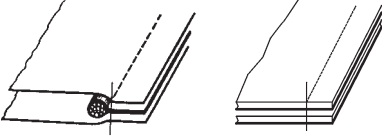
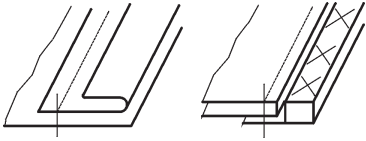
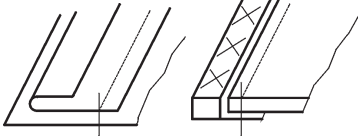
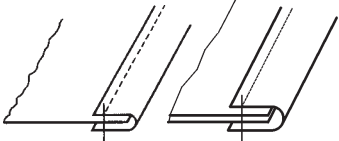
Parts kit	Seam construction	Operation
-6/01 N (N = 6 mm) C medium weight material		Standard parts kit for all types of sewing work, e.g.: <ul style="list-style-type: none"> • Closing seams • Edge sewing work on fitted covers • Fancy seams
-6/01 N9 (N9 = 9 mm) C medium weight material C/D heavy weight material		
-6/07 N9 (N9 = 9 mm) C medium weight material		Climbing parts kit for closing seams and top-stitching work with thick cross seams
-6/13 N9 (N = 9 mm) C medium weight material		Parts kit for closing seams on quilted covers
-40/12 N (N9 = 9 mm) C medium weight material For piping sizes from 3 - 10 mm (standard: 7 mm)		Piping parts kit (side adjustment of presser foot) for pre-piping and piping work
-40/14 N (N = 6 mm) C medium weight material For piping sizes from 5 - 11 mm (standard: 5 + 7 mm)		Piping parts kit for piping work (pre-finished piping), very suitable for different piping sizes, as only the presser foot has to be changed. Alternative: Closing seams on foam-backed or fleece-backed fabrics / leather without piping
-2/04 N (N = 6 mm) C medium weight material Top-stitch width: 1.5 (standard), 2, 3, 4 mm		Work on right edge e.g. <ul style="list-style-type: none"> • Attaching fastening sections • Sewing zip on one side
-3/04 N (N = 6 mm) C medium weight material Top-stitch width: 1.5 (standard), 2, 3, 4 mm		Work on left edge e.g. <ul style="list-style-type: none"> • Attaching fastening sections • Sewing zip on one side
-17/01 N9 (N9 = 9 mm) C medium weight material		Binding work



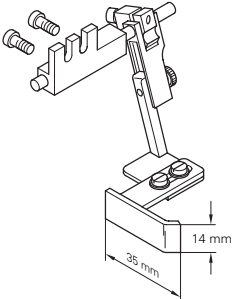
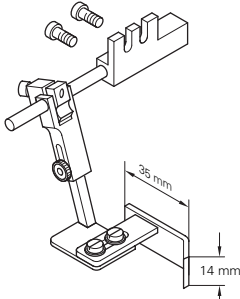
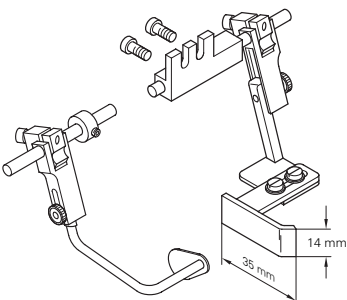
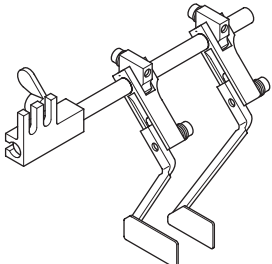
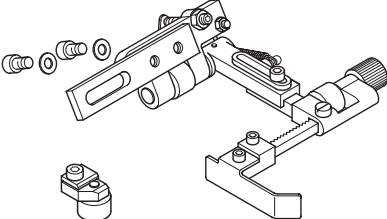





Edge guides

Edge guide	Parts No.	Suitable for parts kit
	91-156 763-91	<ul style="list-style-type: none"> - 2/04 - 6/01 - 6/07 - 6/13 - 40/14
	91-156 764-91	<ul style="list-style-type: none"> - 3/04 - 6/01 - 6/07 - 6/13
	91-156 765-91	<ul style="list-style-type: none"> - 6/01** - 6/07** - 6/13**
	91-156 767-91	<ul style="list-style-type: none"> - 2/04 - 6/01 - 6/07 - 6/13
	91-156 768-91	<ul style="list-style-type: none"> - 2/04 - 6/01 - 6/07 - 6/13 - 40/14

** Presser feet have to be adapted

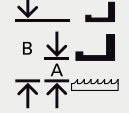

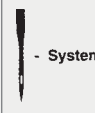
Technical data + Specifications

Typen			Modell							
2235 BASIC 2235 - 021/000	3,000	max. 9	C	3,000 2,500 1,800	1 → 4 4 → 5 5 → 9	A: 9 mm B: 20 mm		134-35	90 - 160	max. 15/3
2235 BASIC 2235 - 032/000	2,800	max. 9	C/D	2,800 2,500 1,800	1 → 4 4 → 5 5 → 9	A: 9 mm B: 20 mm		134-35	130 - 180	max. 10/3
2235 PLUS 2235 - 521/001	3,000	max. 9	C	3,000 2,500 1,800	1 → 4 4 → 5 5 → 9	A: 9 mm B: 20 mm	≤ 12	134-35	90 - 160	max. 15/3
2235 PLUS 2235 - 532/001	2,800	max. 9	C/D	2,800 2,500 1,800	1 → 4 4 → 5 5 → 9	A: 9 mm B: 20 mm	≤ 12	134-35	130 - 180	max. 10/3
2235 PREMIUM 2235 - 821/001	3,000	max. 9	C	max. 3,000 (Speed adapted on stroke)		A: 9 mm B: 20 mm	≤ 12	134-35	90 - 160	max. 15/3
2235 PREMIUM 2235 - 832/001	2,800	max. 9	C/D	max. 2,800 (Speed adapted on stroke)		A: 9 mm B: 20 mm	≤ 12	134-35	130 - 180	max. 10/3

C medium weight material

C/D medium weight material
and thick threads



Max. sewing speed

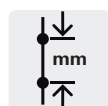

Max. stitch length



Max. sewing speed
depending on feed stroke

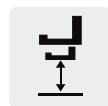

Stroke of the alternating
sewing feet



Top feed stroke (A) and
fabric clearance (B)



Remaining thread length after
cutting in mm



Needle system

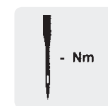

Recommended
needle size in Nm

C:345 x D:120	●	●	●						●	
C:345 x D:120	●	●	●						●	
C:345 x D:120	●	●	●	●	○	●	●		●	
C:345 x D:120	●	●	●	●	○	●	●		●	
C:345 x D:120	●	●	●	●	●	●	●	●		●
C:345 x D:120	●	●	●	●	●	●	●	●		●

● standard
○ option

- Thread size (metrical number in Nm)
- Arm clearance in mm
- Number of needles
- Bottom feed, needle- and alternating unison feed

- Horizontal hook , large
- Thread trimmer
- Thread nipper
- Presser foot lift

- Automatic back-tacking
- Control for two different stitch lengths
- Top feed lift adjustable by knob
- Top feed lift pre-selectable and recallable by knuckle switch, with automatic speed limitation

PFAFF Industriesysteme und Maschinen AG

Hans-Geiger-Str. 12 – IG Nord
D – 67661 Kaiserslautern
www.pfaff-industrial.com

Telefon: +49-6301/3205-0
Telefax: +49-6301/3205-3171
E-mail: info@pfaff-industrial.com

