

PFAFF[®] Industrial

New

2571 ME

2574 ME

2591 ME



by PFAFF[®] Industrial
Made
in Germany

Philosophy

The progressive design of the new 2571/2574/2591 ME * makes a distinctive mark in the Shoe Machine world. Its clearly designated functions support and enhance the working environment of the operator. The streamlined and modern appearance of the machine, in conjunction with its user friendly functions, easily conveys the high quality of Pfaff Post Bed shoe machines. This new range from Pfaff, incorporating the most modern mechatronic innovations, will surely strengthen Pfaff's reputation in the market place. No other Shoe machines are as precise and effective in shoe production. With the new 2571/2574/2591 ME *, Pfaff ideally combines the unique POWERLINE design with the proven high tech "Made in Germany".

The new 2571/2574/2591 ME * possesses everything required to ensure the recovery of decades of market leadership.

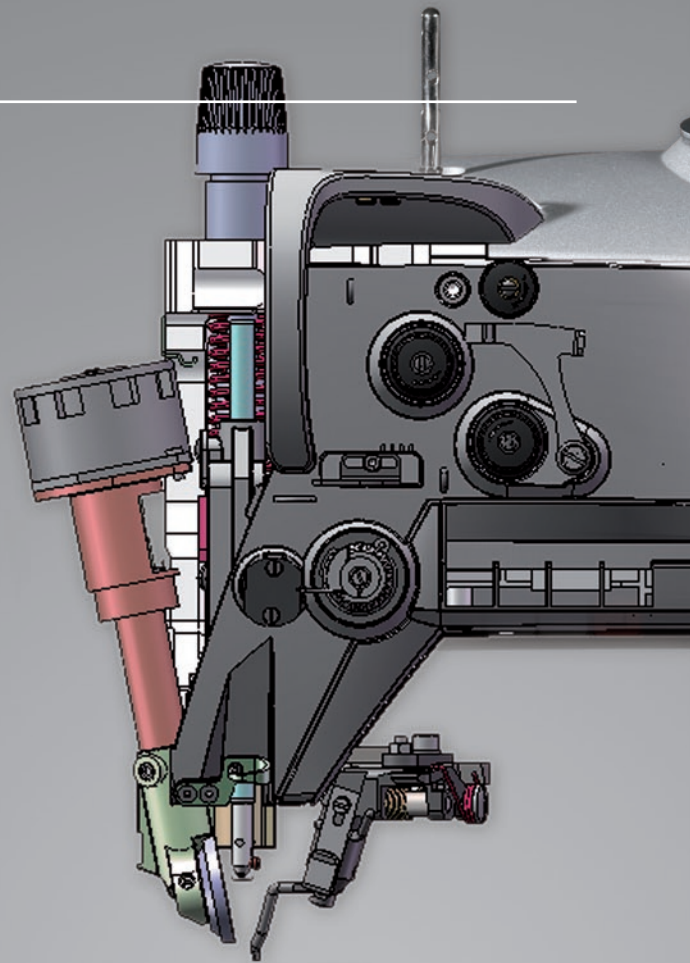

PF AFF 2591: Post-bed, right



PF AFF 2571: Post-bed, left



PF AFF 2574: Double-needle

- * ME = Mechatronic
- ✓ less moving parts
- ✓ simple service and handling
- ✓ highly dependable

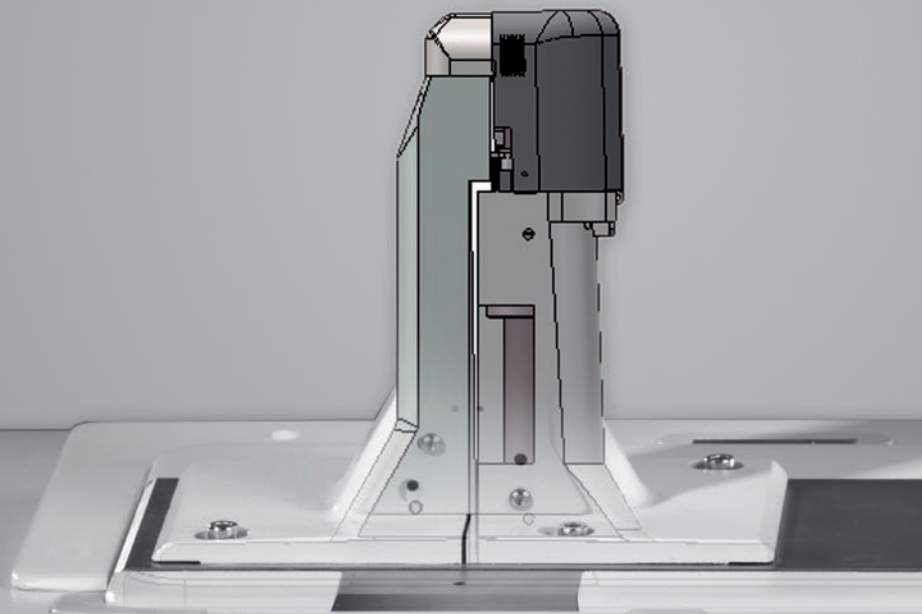



PFAFF 2591

Control panel with LCD screen and buttons. The screen displays 'A B C D'. Below the screen is a safety warning label with various icons.

100
90
80
70
60
50
40
30
20
10
0

Features

Features of the **PLUS** version:

- Best quality stitching for all decorative and assembly seams
- Greater ease of handling due to enlarged area around the needle and roller presser (clearance under machine arm: 345 x 290 mm)
- No air pressure required
- Guaranteed „stitch in stitch“ backtacking – no “perforation” of material
- Stitch length settings are identical from machine to machine
- Accurate stitch length can be reproduced at any time
- Seam length programming by control panel
- Sturdy, easily adjustable thread trimmer with short thread ends
- Electromagnetically controlled functions for thread trimming and presser foot lifting
- Simple adjustment of stitch length and number of backtack stitches via control panel
- Secured seam start due to electronic start sequence
- Software-update via serial interface possible
- High torque due to direct drive – the machine runs smoothly
- LED light integrated in head of machine (option)
- Integrated multi-function buttons on machine head (Reverse sewing/intermediate backtacks, 1/2 stitch, single stitch, secure switch)

- Option: Reliable edge trimming device (sub-class -725) for the 2571 and 2591 machines



Expanded features of the **PREMIUM** version:

- Programmable S3 operator panel with SD-card reader for simple importing and transferring of programs.
- Hot key for backtacking
- Differential feed is available during the sewing operation
- Knee switch for quick change of sewing sections
- SD-card with software in order to activate the machine
- LED light integrated in head of machine



Unique service concept

Easy and fast access to all adjustments:
The top arm cover and the head cover can be removed after loosening just 3 screws.

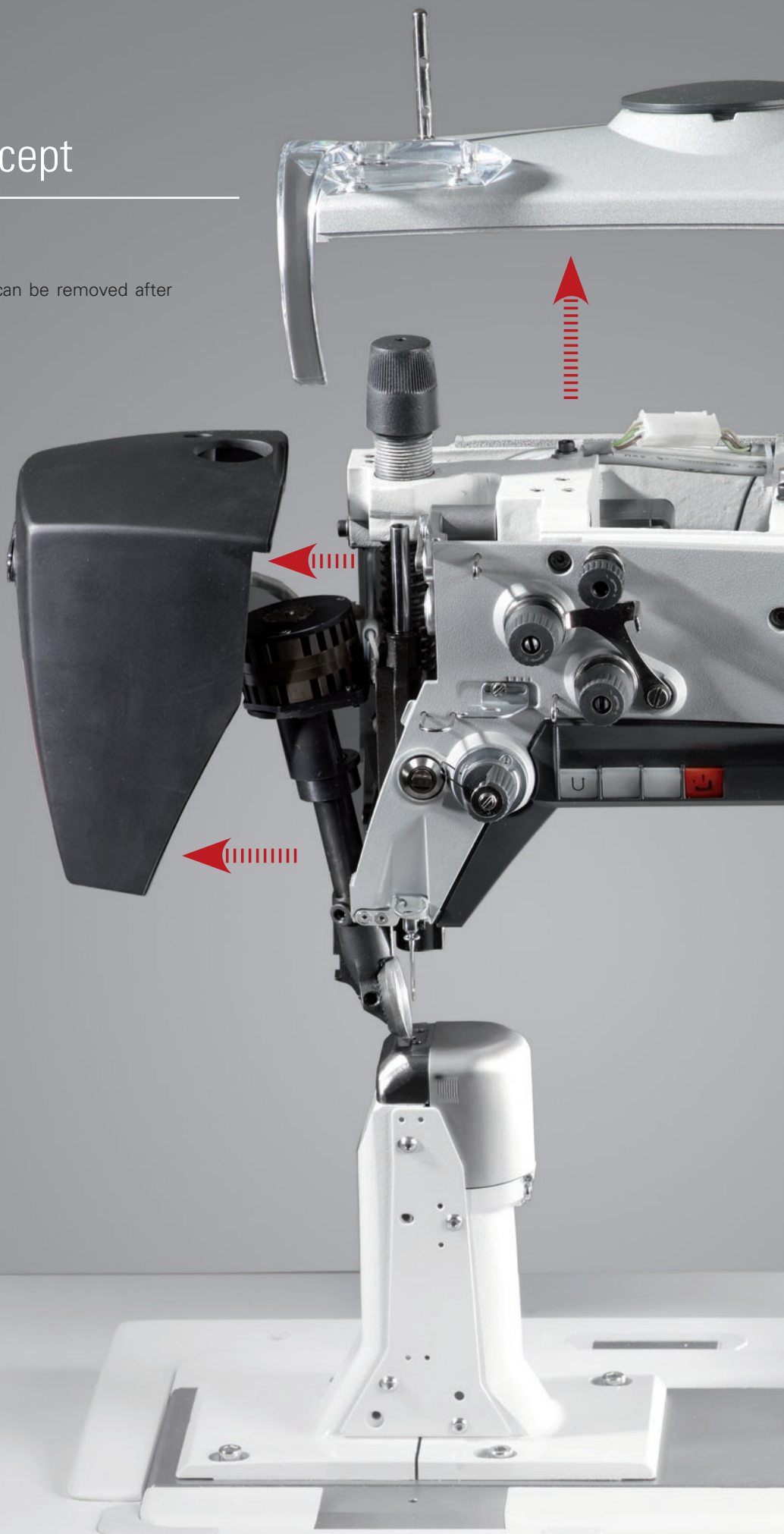
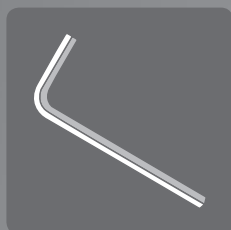



PFAFF 2591



Lubrication system

The New Lubrication system, which enables precise control of the fresh oil supply to the hook, eliminates any oil leakage and soiling of the workpiece.

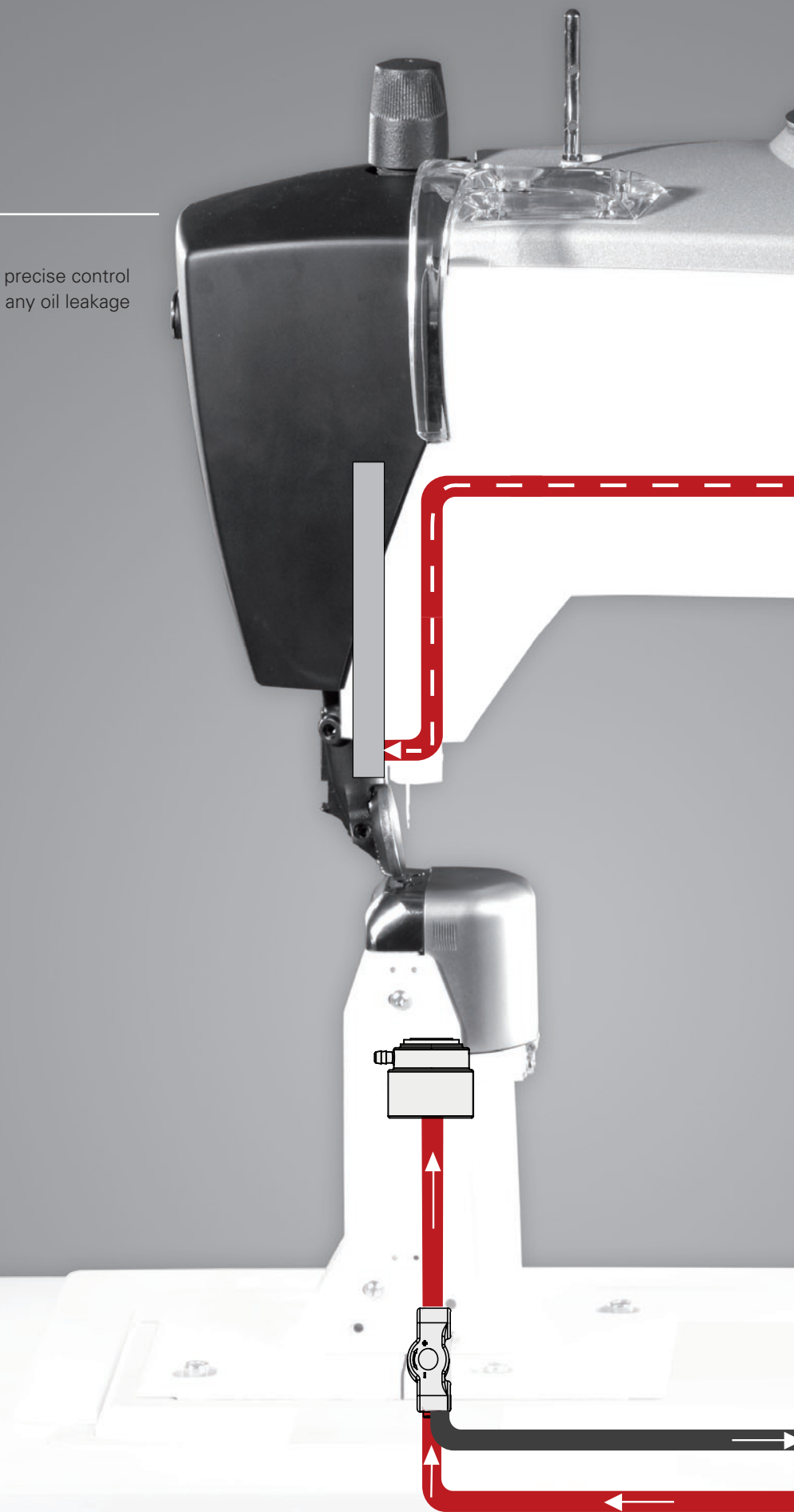
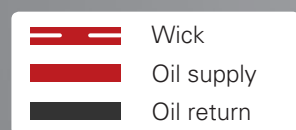

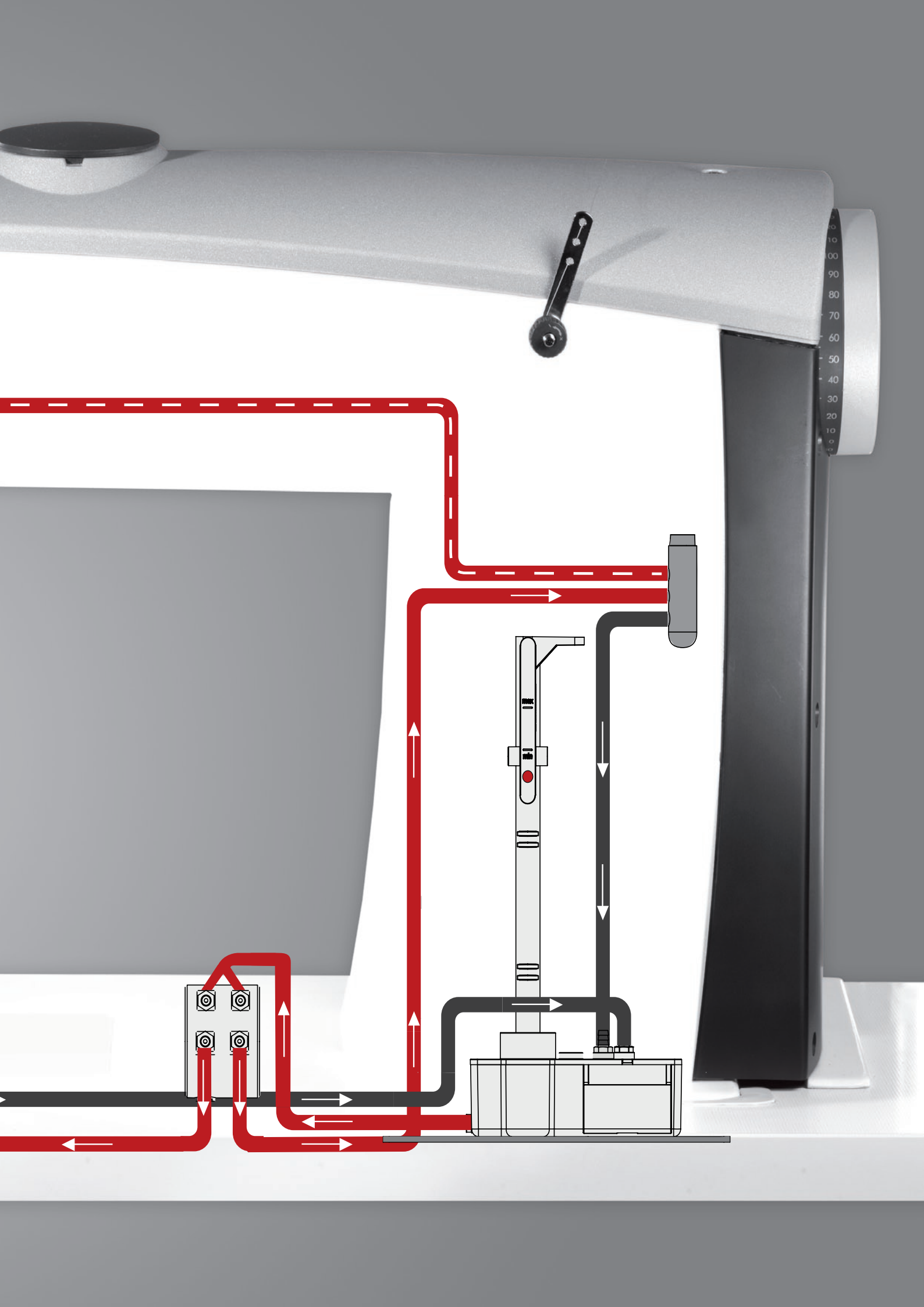

Specifications

Versions:

25	x	x	-	x	1	x	/	x	x	1
7 = Post-bed, left 9 = Post-bed, right	1 = One Needle 4 = Two Needle	5 = Plus version 8 = Premium version	small hook (22 mm)	3 = A version 0 = B version 1 = C version	0 = without edge trimmer 2 = with edge trimmer -725/04	0 = right hook 1 = left hook	Thread trimmer for threads up to 20/3 syn.			

Remarks:

All machines are equipped with:

- Electronically controlled backtacking device with additional hand switch at machine head for intermediate tacking
- Electro-magnetically controlled roller presser lifting with additional knee switch for intermediate roller feet lifting; no compressed air required

The roller presser needs to be mentioned in your order as a separate position:

- Roller presser, driven (30 mm): No. 91-263 829-90
- Roller presser, driven (35 mm): No. 91-263 833-90

Technical data:

Stitch type:	301 lockstitch
Needle system:	134
Clearance under: roller presser	7 mm
Sewing speed:	max. 3,500 s.p.m.
Stitch length:	max. 5 mm
Net weight of head:	approx. 87 kg (net) / approx. 97 kg (gross)

Our Customers, our Partners

CAPRICE
laufen auf luft

Dockers
by Gerli
Boots & Shoes

PUMA

MEINDL
Shoes For Actives

DORNDORF

daytona
FREY

ecco **vivantica**

KangaROOS
SuperShoes

Josef Seibel
THE EUROPEAN COMFORT SHOE

K+S shoes

LOWA
Outdoor- & Skiboots

Antilopa

Shoes for
HAIX
Professionals

PEPINO
Die kleinen Feinen von
RICOSTA

RICOSTA

REMONTE

**Finn
Comfort**
Made in Germany

**han
wag**

rieker
ANTISTRESS

Sioux
DAS MOKASSIN GEFÜHL

Van Dal

ara
SCHUHMODE,
DIE PASST.

adidas

jjela

atlas
the shoe company

LLOYD

solidus
Comfortschuhe

BALLY **ROHDE**

PETER KAISER
SCHUHMACHER SEIT 1838

SALAMANDER

Semler
DER SCHUH
SEIT 1863

RoniKids

Gabor
shoes &
fashion

PFAFF Industriesysteme und Maschinen AG

Hans-Geiger-Str. 12 – IG Nord
D – 67661 Kaiserslautern
www.pfaff-industrial.com

Telefon: +49-6301/3205-0
Telefax: +49-6301/3205-3171
E-mail: info@pfaff-industrial.com

