

**PFAFF**<sup>®</sup> Industrial

**5483**

Ultra-high-speed chainstitch seamer  
with drop feed



# PFAFF 5483

## Special features:

- Usable in all branches of the sewing industry.
- Maximum sewing speed: 6,000 s.p.m.
- Optimum sewing reliability, even at maximum speed.
- Very good feed characteristics at low foot pressure.
- Low-noise, low-vibration running, even at top speed.
- Conveniently arranged controls.
- Infinitely variable stitch length.
- Easy maintenance, due to:
  - centralized fresh-oil lubrication of needle bar and hook drive
  - maintenance-free anti-friction bearings
  - enclosed gearcase with long-life pad lubrication
  - built-in adjustment gauges for quick and reliable adjustment
- High sewing output and simple operation, due to time- and cost-saving work aids, such as:
  - thread trimmer,
  - automatic foot lift,
  - backtacking system,
  - needle positioning system, etc.
- Standardized parts within the 5480 Series, thus lower costs in store-keeping.

## Stitch type:

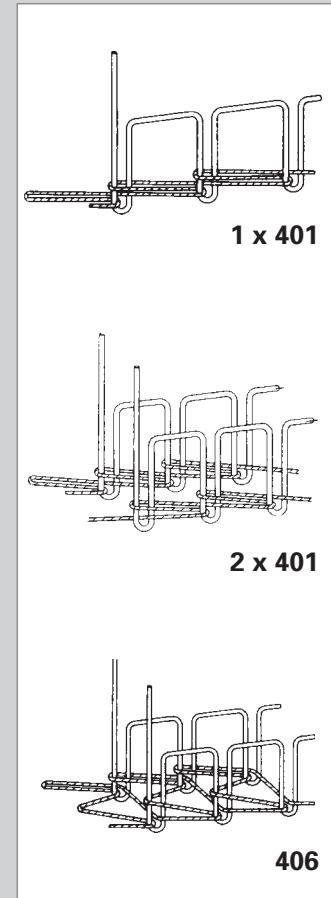

- H** = Needle bar stroke 33 mm
- B** = For sewing medium materials, needle size (Nm) in 1/100 mm: 80 to 100
- S** = Machine version for sewing fabrics

<b>Standard sales range:</b>	Thread trimmer-90071	Foot lift-910/04	Foot lift and puller lift-948/26	Stitch condensation-917/85	Backtacking system-911/85	Stitch type	Needle gauge in mm	Air filter/regulator-925/03	Max. speed, r.p.m., depending on material and operation	Needle system	Max. stitch length
<b>Single-needle versions</b>											
5483-814/01-6/01 BS						401			6,000	4463-35	4.5
5483-814/01-6/01-900/71 BS	●					401	●		6,000	4463-35	4.5
5483-814/01-6/01-900/71-910/04-917/35 BS	●	●		●		401	●		6,000	4463-35	4.5
5483-814/01-948/26-6/01 BS						401			6,000	4463-35	4.5
5483-814/01-6/01-910/04-917/35-948/26 AS		●	●	●		401	●		6,000	4463-35	4.5
5483-H-814/01-6/01-900/71-910/04-911/35 BS	●	●			●	401	●		4,800	5463-35	4.5
5483-H-814/01-6/10-900/71-910/04-911/35 BSN3.5	●	●			●	401	●		4,800	5463-35	3.5
5483-H-814/01-6/01-900/71-910/04-917/35-948/26 AS	●	●	●	●		401	●		4,800	5463-35	4.5
<b>Two-needle versions</b>											
5483-814/06-94/01 BS x 6.0						406	6.0		5,500	4463-35	4.5

## PFAFF 5483-814/01-6/01-948/26 Single-needle version

High-speed sewing unit with intermittent puller feed, specifically for long closing seams with matching material plies.

The puller rollers in the different widths 10 mm (standard), 15 mm, 20 mm and 30 mm enable a wide range of applications.

### Features:

- Efficient sewing of side and in seams, as well as lining seams
- The intermittent puller feed motion and a pre-selectable roller pressure ensure smooth seams
- Puller feed stroke and pressure can be adapted to the workpiece easily on the control panel
- The all-purpose machine - the puller can be raised, stopped and swung out of the work area manually
- Puller unit can be shifted to the side of the needle
- Super-precision parts sets for optimum feed quality
- „Flash facility“ for software updates without changing the E-prom and without opening the control unit



## PFAFF 5483-814/06-94/01 Two-needle version

Two-needle high-speed covering-stitch seamer for edge-stitching fabric edges and top-stitching, e.g. for making up belt loops.

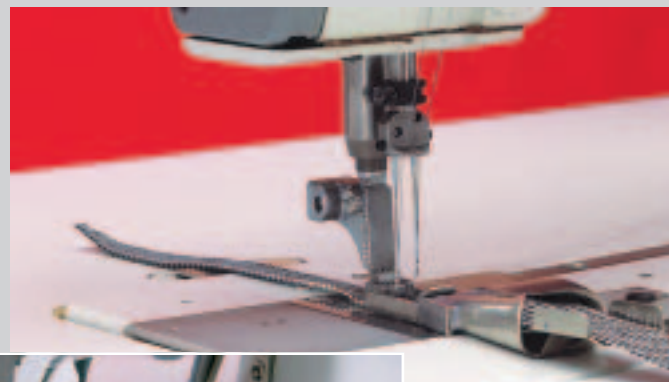
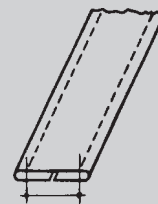

## Subclasses and work aids of the PFAFF 5483:

### Subclasses:

#### **Single-needle version:**

##### **-6/01**

For plain seaming operations, standard part set shape.

##### **-6/10**

Bridge-type part set with tandem foot, special for seat seams

#### **Two-needle version:**

##### **-6/01**

For plain seaming operations, standard part set shape. Standard needle gauges: 2.4, 4.8, 6.4 and 10.0 mm

##### **-94/01**

For folding both sides of a tape downwards and top-stitching them, e.g. belt loops

### Work aids:

#### **-900/71 Thread trimmer**

Electro-pneumatically controlled.

#### **-910/04 Automatic foot lift**

Electro-pneumatically controlled.

#### **-911/35 Backtacking system**

Electro-pneumatically controlled.

#### **-917/35 Stitch condensation**

Electro-pneumatically controlled.

#### **-925/03 Air filter/regulator**

## **Technical data:**

### **Stitch type:**

see table

### **Max. sewing speed:**

see table

### **Balance wheel:**

65 mm eff. dia.

### **Motor power:** 0.550 kW

### **Max. stitch length:**

see table

### **Needle system:**

see table

### **Fabric clearance:**

7.0 mm or 9.0 mm at 5483-H

### **Clear work space:**

260 x 130 mm

### **Bedplate dimensions:**

476 x 177 mm

### **Net weight (head only):**

approx. 37 kg

### **Gross weight (head in carton):**

approx. 45 kg

### **Carton dimensions (head):**

70 x 30 x 54 cm

This machine is equipped with finger-guard,  
belt- and take-up lever guards as standard.

### Hotlines:

Technical service: +49-175/2243-101

Application consultancy: +49-175/2243-102

Spare-parts hotline: +49-175/2243-103



**Europäische Union**  
Wachstum durch Innovation – EFRE



**PFAFF Industriesysteme  
und Maschinen AG**

Hans-Geiger-Str. 12 – IG Nord  
D-67661 Kaiserslautern

Telefon: +49-631/200-0

Telefax: +49-631/17202

E-mail: [info@pfaff-industrial.com](mailto:info@pfaff-industrial.com)

Printed in Germany  
engl.  
296-12-18793 04/08